

Rysunek 1

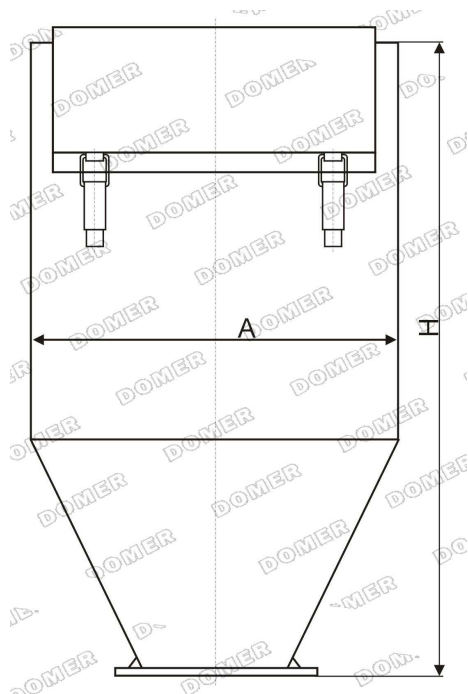

Rysunek 2

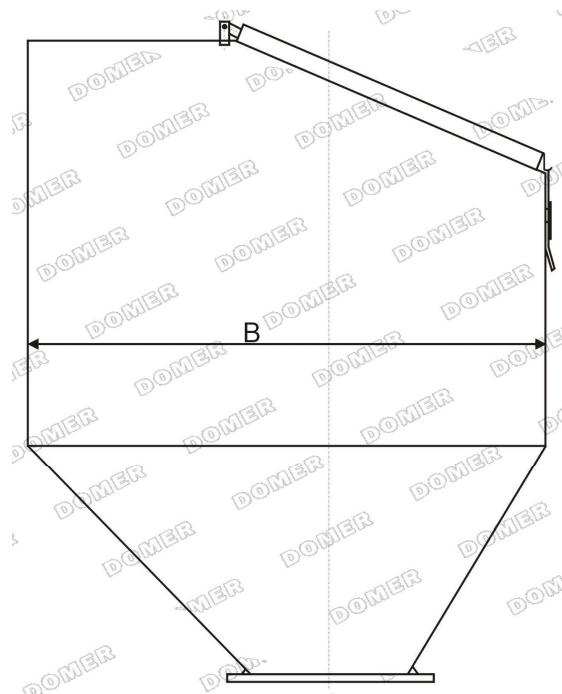

Rysunek 3 – Kołnierz przyłączeniowy



Tabela wymiarowa

Parametr	Wartość
A	800 mm
B	950 mm
H	1200 mm
L1	240 mm
L2	220 mm
L3	190 mm
L4	210 mm
Pojemność	700 dm ³

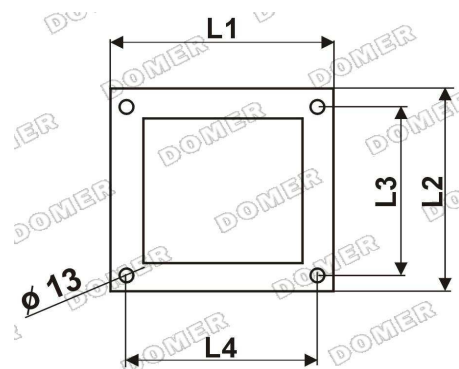