

Rysunek 1

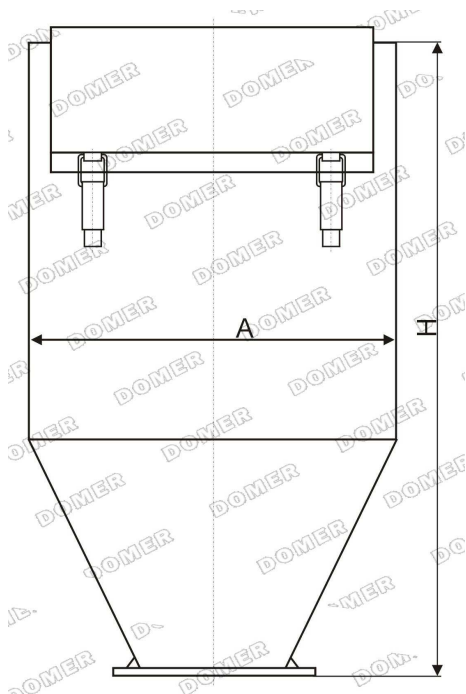

Rysunek 2

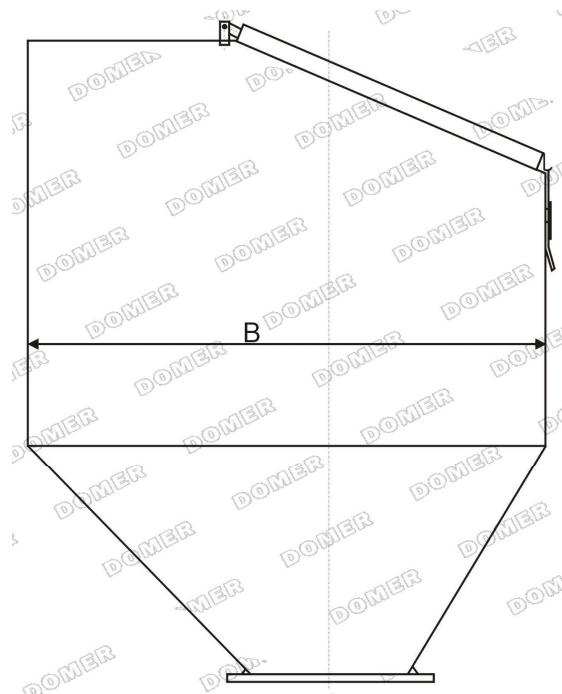

Rysunek 3 – Kołnierz przyłączeniowy



Tabela wymiarowa

Parametr	Wartość
<b>A</b>	500 mm
<b>B</b>	600 mm
<b>H</b>	900 mm
<b>L1</b>	250 mm
<b>L2</b>	170 mm
<b>L3</b>	200 mm
<b>L4</b>	130 mm
<b>Pojemność</b>	215 dm <sup>3</sup>

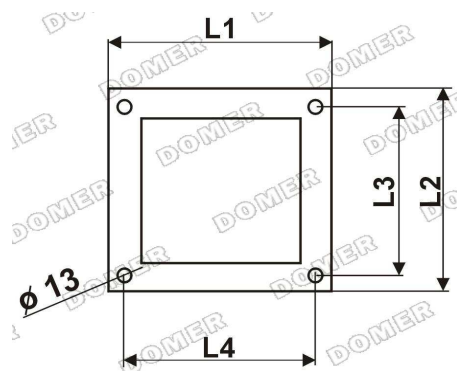